

FURUNO

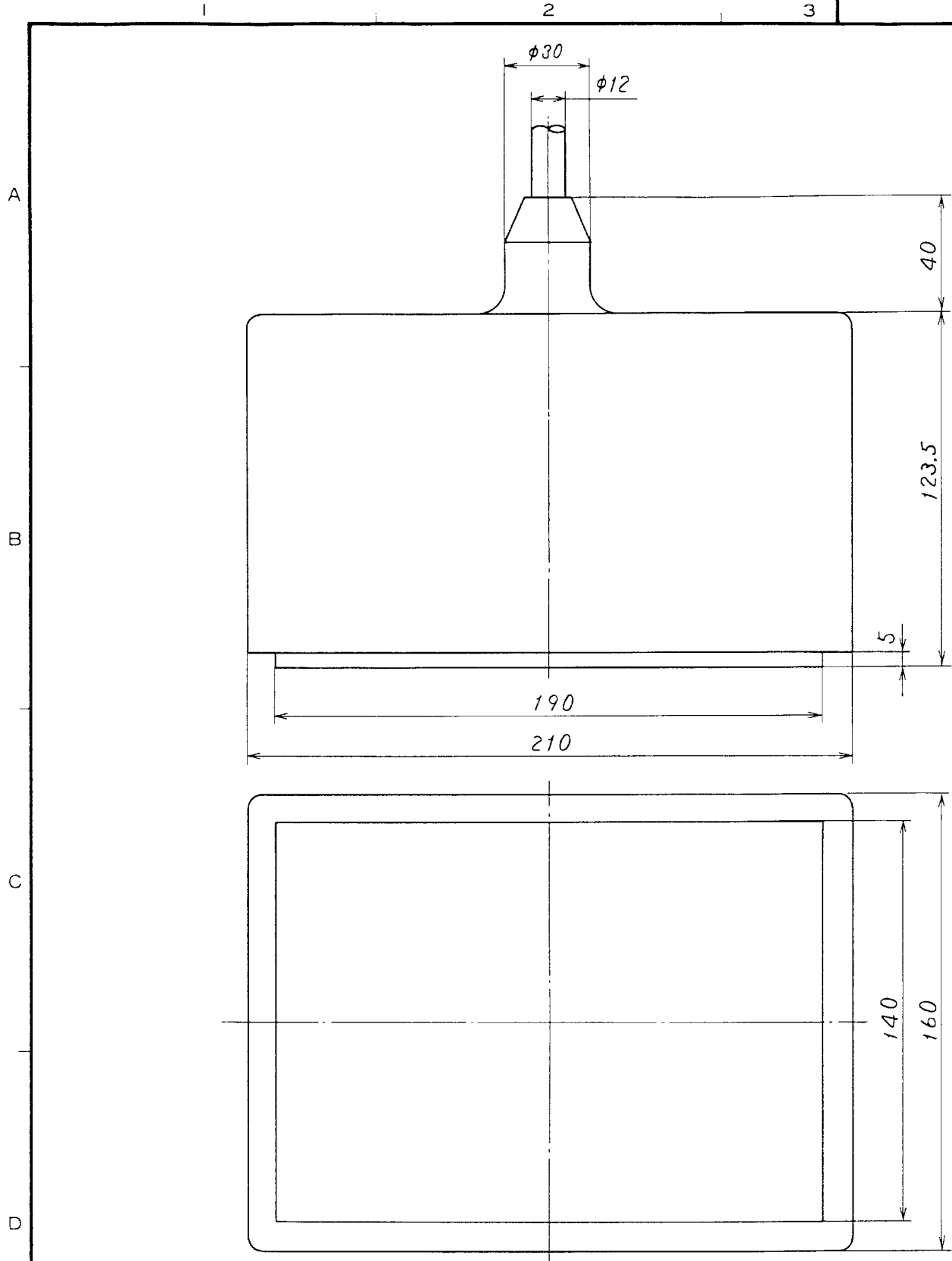

品番 ITEM	品名 NAME	材質 MATERIAL	数量 QTY	図番 DWG.NO.	摘要 REMARKS
承認 APPROVED	三角法 THIRD ANGLE PROJECTION				名称 TITLE
検 CHECKED	尺 SCALE				50F-24H 送受波器外觀図 TRANSDUCER OUTLINE
製 DRAWN	重 WEIGHT				図番 DWG.NO.
	7 (15mケーブル) kg				C2003-041-A

FURUNO ELECTRIC CO., LTD.